

## Foam Tendency Analyser – FTA100



- Predicts foam before it happens.
- Reduces Costs - Adds antifoam only when necessary.
- Prevents foam in inaccessible places – e.g. sewers & drains.
- Generates an early warning of foam.
- Fully Automatic Operation

### DESCRIPTION

The FTA100 is a unique Foam Control System that provides a pre-emptive rather than reactive approach to foam control. Operating fully automatically, it measures the tendency of a liquid to create foam and can take action before it happens in a process by taking a sample from the process and analysing the foam tendency in a small test cell. Foam can be created in the cell before it occurs in the plant, by modelling the process which could create foam.

The system uses Charis Technology's unique IMA Sensing technology to sense and control foam reliably by means of a Foam Sensor. Charis Foam Sensors are designed for highly reliable foam control even if coated with a sticky build-up on the surface.

The FTA100 is designed primarily for low maintenance and will operate for long periods without attention. The test cell can be easily removed to rinse out any debris that builds up, when necessary.

The FTA includes an anti-foam pump to control the foam and can generate a signal to a process controller or an alarm.

### TYPICAL APPLICATIONS:

- Sewers and drains which are inaccessible for foam detection.
- Transport water which flows around large processes e.g. chip manufacture.
- Public Fountains and Water Features.
- Systems where foam must never occur.
- Outflows to rivers.

## OPERATION

The FTA includes a series of pumps for sample handling. A fill pump is used to draw a sample from a process into the test cell. The sample in the test cell is analysed by sparging air through it to create foam. The foam is then measured using a Charis sensor. Once the measurement is complete the sample is removed by means of the drain pump, and returned to the process or discarded.

The system can be set to act as an early warning to generate foam before it occurs elsewhere. Alternatively it can be used to simulate a process to indicate that foam is being generated.

A built in error detection system prevents the pumps running if the sample is not flowing correctly. For example if the test cell does not fill then the system will generate an error.

## Schematic Diagram of FTA100

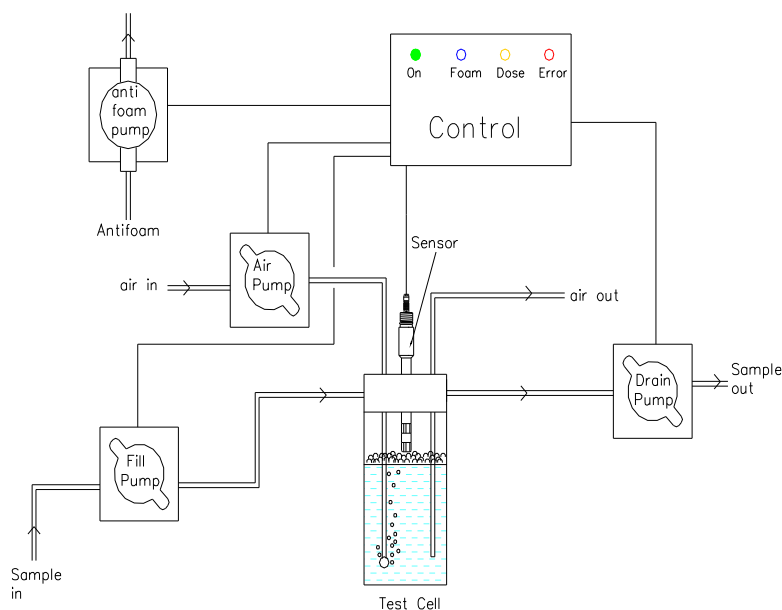

## SPECIFICATION

Power Supply	110 or 230 Volts a.c., 50/60 Hz,
Indicators	Power : On when the unit is powered-up. Foam : On when foam is measured Pumping : On when the pump is actuated Error : On when an Error is found
Antifoam Flow Rate	0 – 5 L/hr
Sample Volume	200mL
Sample Rate	1 sample every 4 mins.
Sensitivity	0.35K to 100K ohms impedance.
Fouling Immunity	Sensitivity to fouling <1% of sensitivity to foam with Charis Sensors.
Enclosure	Wall mounting, IP65
Dimensions	Height 500 Width 510, Depth 200 mm (enclosure)
Connections	Cable entry via PG11 cable gland, Liquid via 10mm push fit.